



## Thermostuctural analysis of a Mobile Blancher Component

June, 2011



\* M.G. Harkare \*\* G.U.Shinde \*\*\* Dr.B.M.Dabade

\* Dept. of Mechanical Engg., MGM'S College of Engineering, Nanded (MS), India.

\*\* College of Agriculture Engg. & Tech., M.A.U. Parbhani (MS), India.

\*\*\* Prof. of Production Engg, S.G.G.S. Institute of Engg. & Technology, Vishnupuri, Nanded (MS)

### ABSTRACT

The process analysis and design testing of a turmeric heat treatment is software tested. The heat transfer medium is steam, which improves rate of energy consumption, process time, turmeric contents and its properties and the process handling system. The Geometric solid model is prepared in the LS-DYNA software for design and thermal analysis. The analysis is done by meshing and applying thermal environmental conditions in the software to stimulate the heat treatment process. The analysis derives a scope to optimize the stresses heat distribution to improve overall efficiency of the process.

**Keywords :** blancher, turmeric steam cooker, heat treatment

### Introduction :

India ranks first in production of turmeric i.e. 701.16 Lac tones from 185.32 lac hectare Of Area.(Varshney et al 2004 ). Maharashtra produces about 200 MT from 700 hectare area (Vikas 2003). Turmeric powder is used as spice and as a food coloring agent in pickles, chutneys, curries and other culinary preparations, as a drug and in cosmetic and in ayurvedic Medicine. The deep yellow color of turmeric is due to cur cumin and aromatic flavor.

Cur mumun can be extracted by Methanol, ethanol, acetone and dichloro ethylene. Turmeric is a cash crop in Marathawada and Vidharba region of Maharashtra.

The traditional method of turmeric processing uses cowdung extract and lead Chromate base for boiling, was found hazardous to the health. It has many drawbacks such as

\* Uneven heating of rhizomes.\* Loss of characteristics of turmeric, like loss of cur cumin and oleoresin during handling of rhizomes. \* Huge labor cost.

\* Huge losses in handling, loss of fuel, time consuming and increases cost of processing.

This research work is carried out to reduce these losses and the cost of processing is reduced.

### 2. Material property details.

The details of the structural material S.S. 304L of which blancher is made of are mentioned in the table 1.1. The analysis is being attempted with existing material test reports. The tensile/yield stress, elongation on values are considered for test

### 3. FEM Model of Blancher

The thermal analysis was carried out by finite element package ABAQUS. Heat Transfer, quadratic and eight noded heat transfer quadrilateral shell [ DS8] were chosen for thermal analysis as shown in

| Material properties of SS 304L. |   |                                       |
|---------------------------------|---|---------------------------------------|
| Sr.                             | Material specifications                     | Typical values                        |
| 1                               | Young's Modulus (N/mm <sup>2</sup> )        | 196200                                |
| 2                               | Poisson's ratio                             | 0.29                                  |
| 3                               | Density (kg/mm <sup>3</sup> )               | 8.00E-06                              |
| 4                               | Coefficient of thermal expansion (mm/mm/°C) | 17×10 <sup>-6</sup>                   |
| 5                               | Thermal conductivity (W/mmK)                | 0.0163 and 0.0214 at 25 °C and 500 °C |
| 6                               | Specific heat (J/kgK)                       | 500 and 563 at 25 °C and 400 °C       |
| 7                               | Emissivity (polished surface)               | 0.11                                  |
| 8                               | Tensile strength (MPa)                      | 554 (from material test certificate)  |
| 9                               | Yield strength (MPa)                        | 281 (from material test certificate)  |
| 10                              | Elongation (%)                              | 44 (from material test certificate)   |

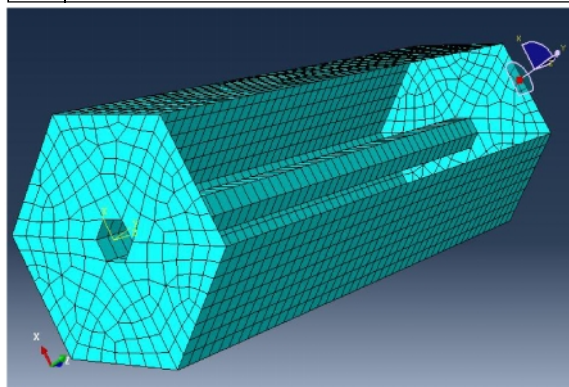

Fig.1.1

fig. 1.1. The thickness of Blancher component of shell is one mm. Boundary and loading conditions: The complete blancher model is made of steel and having thickness one mm. The material properties of SS 340L are as in Table – 1.1

**Thermal Loading :** Fig.1.2 Shows thermal loading conditions. Uniform temperature of the Blancher is kept at 500c , 750c, 1000c,1250c. Transient thermal analysis to obtain Heat Flux plot at various temperature and time. The heat released by steam in the inner pipe of the Blancher is at 2000c.

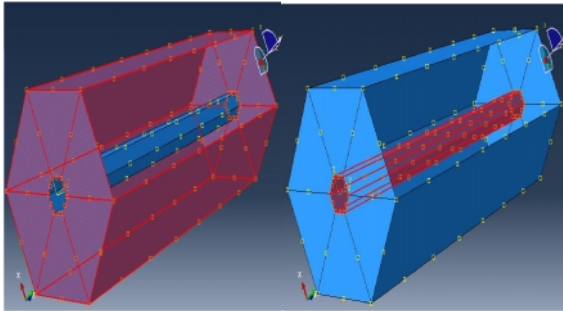

Fig. 1.2

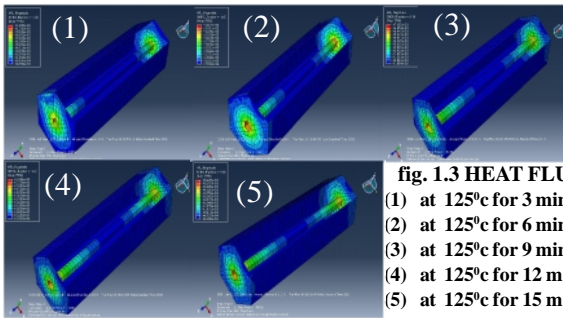
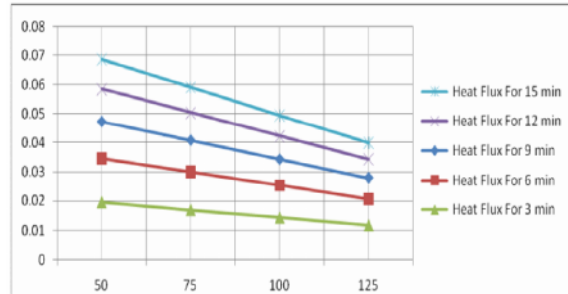

fig. 1.3 HEAT FLUX  
 (1) at 125°C for 3 min  
 (2) at 125°C for 6 min  
 (3) at 125°C for 9 min  
 (4) at 125°C for 12 min  
 (5) at 125°C for 15 min

pipe temperature for three minutes. In second case the blancher surface temperature is changed to 750c. In third and fourth cases the Blancher surface temperature is changed to 1000c and 1250c. Similarly fifth to eighth load cases are considered for six minutes, Eighth to twelve load cases for nine minutes, thirteenth to sixteenth for twelve minutes and seventeenth to twentieth for fifteen minutes. Since twelve to fifteen minutes are sufficient to cook the Rhizomes in actual traditional method.



**Conclusions :** The thermal analysis of the Blancher had been carried out using ABAQUS. The Blancher under thermal temperature maximum 2000c to get the heat flux. The heat flux is found uniform throughout the blancher for all 20 load cases as in fig.1.3.

It indicates that the turmeric rhizomes can be heated uniformly in the blancher. Practically it was found that 12 to 15 minutes time is sufficient to cook the rhizomes properly. The graph 1.1 shows uniform distribution of heat flux at different load conditions.

The uneven heating of turmeric rhizomes is controlled by a new design of blancher. It is tested by thermal analysis. The handling and labor cost is reduced due to the new design of blancher. The quality and characteristics of turmeric rhizomes were improved due to proper handling of rhizomes. New design of blancher reduces cost of fuel and the total processing cost of turmeric rhizomes.

| Temp ° C | Heat Flux For 3 min | Heat Flux For 6 min | Heat Flux For 9 min | Heat Flux For 12 min | Heat Flux For 15 min |
|----------|---------------------|---------------------|---------------------|----------------------|----------------------|
| 50       | 0.01968             | 0.01501             | 0.01269             | 0.01115              | 0.01004              |
| 75       | 0.01705             | 0.01297             | 0.01087             | 0.009535             | 0.008567             |
| 100      | 0.01443             | 0.01087             | 0.009069            | 0.007919             | 0.007096             |
| 125      | 0.0118              | 0.008711            | 0.007529            | 0.006304             | 0.005625             |

heat flux at 50°C, 75°C, 100°C and 125°C for 3, 6, 9, 12 and 15 minutes. 20 Load cases have been considered. First is at 500c Blancher surface temperature and 2000c inner steam

to operate at different places. Hence it is suggested to implement a mobile blancher for turmeric processing in future.

**REFERENCE**

[1] Zhang L, Wang Y, Chen J. et al. Evaluation of local thinned pressurized elbows [ J]. Int J Pressure vessels and Piping, 2001, 78; 697-703. [2] Ray A K, Sinha S K, Tiwri Y N. Analysis of failed reformer tubes [J] Engineering failure Analysis, 2003, 10; 351 – 362. [3] Prosonjit Santra, Vijay Bedakhale, Tata Rangnath , Thermal structural analysis of SST – 1 vacuum vessel and cryostat assembly using ANSYS. [4] A.S. Sladkiv and V.I Shlemovich, Deflocculating Plastic Clay in a Rotary Blunger – Mill [5] Balashanmugan, P.V. (1991) Processing and curing of turmeric. South Indian Hort., 39(4): 21-4- 216. [6] Krishanmurthy, M.N., Padmabai, R., Natrajan, C.P. and Kuppuswamy, S. (1995). Colour content of turmeric varieties and studies on its processing. J. Food Sci. Technol., 12:12. [7] Purselglove, J.M., Brown, E.G., Gree, C.L., Robbins, S.R.J., (1981). Spices, 2. Longman Group Ltd., London, New York. [8] Varshney, A.K., Garala, S.N. and Akbari, S.H. (2004). Effect of curing on physical characteristics of turmeric J. Agril. Engg., 2: 16- 19. [9] Vikas, S. (2003). India Agricultural 2003. Indian Econ. Data Research Center, New Delhi.